

This instruction sheet is relevant to Phoebe LED Iris Sunset Dim Adjustable Downlight product code: 9981

**THANK YOU for buying this PHOEBE LED product.** To help ensure this luminaire gives complete satisfaction please only use it according to the following instructions, and then pass the instructions to the appropriate person for retention and future reference.

**Warning**

1. Installation only to be carried out by a qualified electrician
2. Please ensure surface is suitable and capable of holding the luminaire's weight
3. Pre-cut hole before installation, (see below chart for hole diameter)
4. Do not operate if product is damaged
5. IP44 rated, suitable for bathroom zones 1-2
6. This product is not suitable for fire rated installations
7. This luminaire must be used with the supplied dimmable driver

The light source of this luminaire is not replaceable; when the light source reaches it's end of life the whole luminaire should be replaced

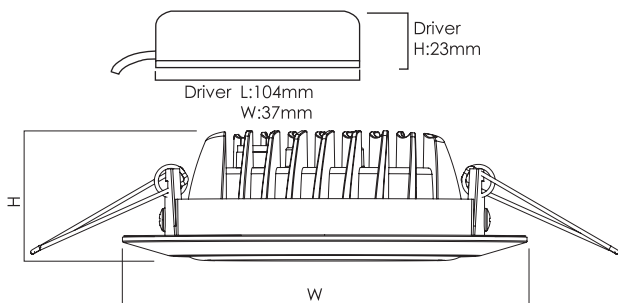

Product code	Power (W)	Colour Temp (K)	Dimensions (mm)		
			H	W	Ø
9981	11.5	1900K to 3000K	32	100	Ø83 ± 2.5

**1**

a. Switch off power  
b. Prepare cut-out hole in your surface to specified dimensions as stated in above table.

**2**

a. Open terminal block cover on driver  
b. Connect to mains electricity AC200-240V in accordance with current wiring regulations, and replace cover.

**3**

a. Place driver into position, within the recess, ensure mounting surface is suitable ta:+50°C tc:+80°C, do not cover with insulating material and ensure the driver has plenty of ventilation.

**4**

a. Push back spring clips and insert luminaire into recess, ensure luminaire is placed with clips horizontal to desired tilt orientation.

**5**

a. Ensure luminaire is a flush fit and has plenty of ventilation, do not cover with insulating material  
b. Tilt to desired position

c. Switch power on at circuit

**NB.** For high voltage circuit insulation testing disconnect mains input supply first  
(Do not circuit test using a Megger)

Images are for information only. Phoebe LED shall not be held liable for improper operation of the luminaire in circumstances where procedures and specifications have not been followed correctly. Crompton Lamps Limited 2017

**Tel:** +44 (0)1274 657 088 **Fax:** +44 (0)1274 657 087 **Web:** www.phoebeled.com