



**HERA**  
DUAL LED  
DOWNLIGHT



This instruction sheet is relevant to Phoebe LED Hera Dual Integrated Downlight part code: 7628.

**THANK YOU for buying this PHOEBE LED product.** To help ensure this luminaire gives complete satisfaction please only use it according to the following instructions, and then pass the instructions to the appropriate person for retention and future reference.

**Warning**

1. Installation only to be carried out by a qualified electrician
2. Please ensure surface is suitable and capable of holding the lamp weight
3. Pre-cut hole before installation, (see below chart for hole diameter)
4. Do not operate if product is damaged
5. This product is not suitable for fire rated installations

**Dimensions - Cut-Out Diameter**

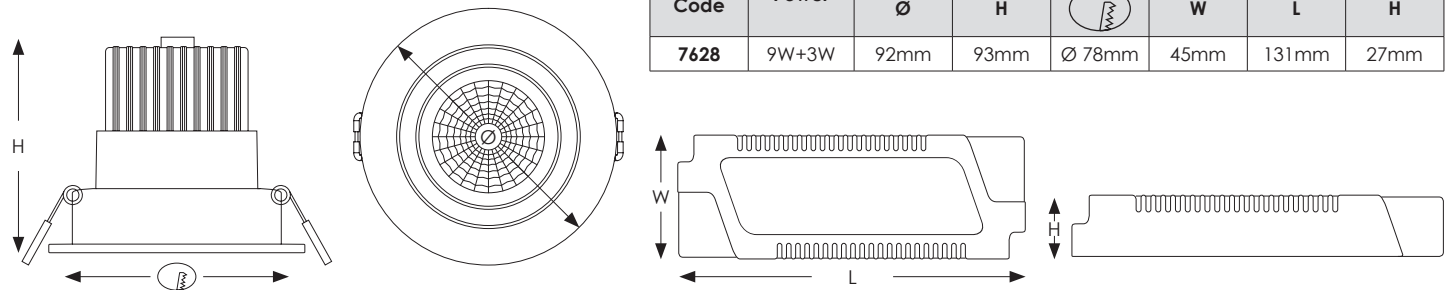

- 1**
- a. Switch off power
  - b. Prepare cut-out hole in your surface to specified dimensions as stated in above table

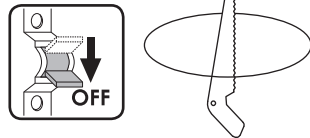

- 2**
- a. Connect driver to 240V mains electricity in accordance with current wiring regulations

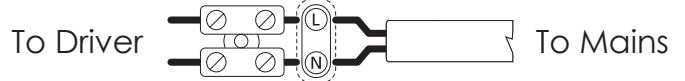

- 3**
- a. Insert driver into recess
  - b. Connect driver to downlight using supplied connect
  - c. Tighten cover to secure the connection

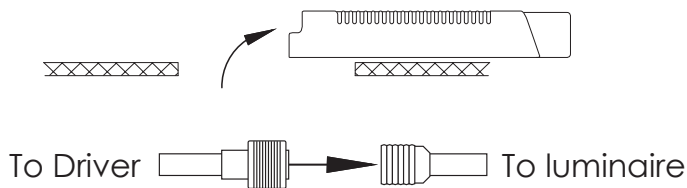

- 4**
- a. Push back spring clips and insert downlight into recess
  - b. Ensure luminaire is a flush fit and has plenty of ventilation, do not cover with insulating material

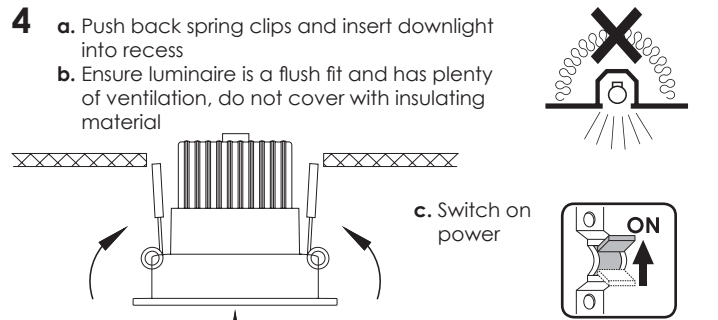

c. Switch on power



**NB.** For high voltage circuit insulation testing disconnect mains input supply first. (Do not circuit test using a Megger)

- 5**
- a. Switch power on/off at the wall switch within 3 seconds to toggle between lighting modes.
  - b. Switch On = Inner Light  
Switch Off/On = Outer Ring  
Switch Off/On = Both Inner Light & Outer Ring

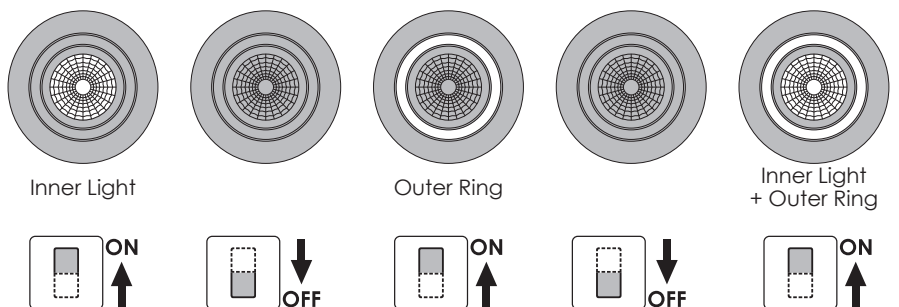

Images are for information only. Phoebe LED shall not be held liable for improper operation of the luminaire in circumstances where procedures and specifications have not been followed correctly. Crompton Lamps Limited 2017

**Tel:** +44 (0) 1274 657 088 **Fax:** +44 (0) 1274 657 087 **Web:** [www.phoebeled.com](http://www.phoebeled.com)