

Atlas LED Commercial Floodlights



Mains operated IP65 Commercial LED Floodlights, ideal for illuminating large areas such as company car parks, industrial grounds or up-lighting buildings.

- Die-cast aluminium with tempered glass lens IK04 Rating
- 30,000 hours average rated life
- 15,000 switching cycles
- Black powder coating
- IP65 rated for indoor or outdoor use
- 4000K colour temperature
- Adjustable bracket to 180°
- 110° beam angle
- Fitted with 1m TRS cable
- Instant full light

Product Code	Watts (W)	Volts (V)	Colour Temp (K)	Useful Lumens (lm)	Total Lumens (lm)	Beam Angle	Dimensions (mm)			Weight (kg)	Order Qty
							W	H	D		
Single Carton											
12103	100	240	4000	8,400	9,900	110°	257	340	59	3.4	1
12110	150	240	4000	13,200	15,600	110°	280	374	63	4.1	1
12127	200	240	4000	17,100	20,200	110°	299	414	69	5	1

Terminal block not included. Installation may require advice from a qualified person

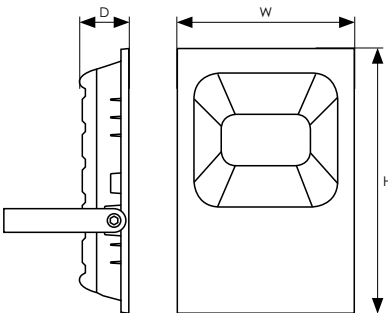

This luminaire contains built-in LED lamps.

The lamps cannot be changed in the luminaire.

CROMPTON LAMPS

LED

874/2012



Lighting brilliance since 1878

Phoebe LED™ is a trading name of Crompton Lamps Limited
 Crompton Lamps Limited registered in England and Wales No. 05590551
 Registered office and correspondence address: Unit 2, Martree Business Park, Bowling Back Lane, Bradford BD4 8QE
Tel: +44 (0)1274 657 088 **Fax:** +44 (0)1274 657 087 **Email:** sales@cromptonlamps.com **Web:** www.cromptonlamps.com

All images and specifications are for illustration purposes only and are subject to change without notice.
 E. & O. E. © Crompton Lamps Limited 2018